

PMH-400 Rev C

|          |     |    |     |
|----------|-----|----|-----|
| DWG. NO. | SHT | OF | REV |
| B-283508 | 1   | 1  |     |

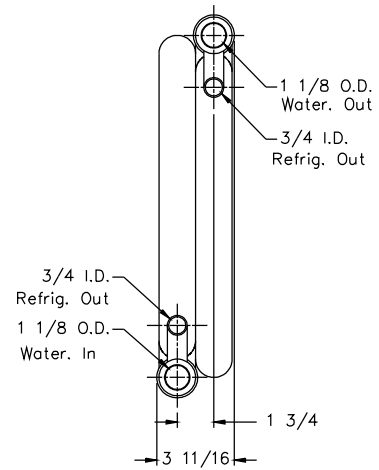
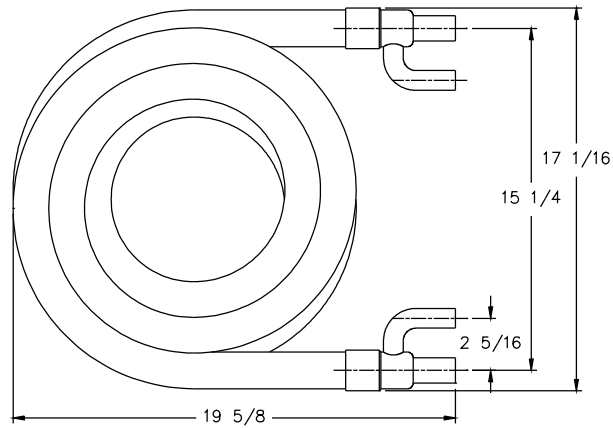

| LTR | REVISIONS | DATE | APPR'D |
|-----|-----------|------|--------|
|     |           |      |        |

©2009 Packless Metal Hose, Inc. All Rights Reserved. No rights or licenses, whether express, implied, arising by estoppel, or otherwise are granted or conveyed. Packless Metal Hose, Inc. is the owner of all worldwide rights, titles, and interests in and to the content of the drawings and all intellectual property rights therein, including, but not limited to, all rights and copyrights. Any use of any of the drawings without the express written approval of Packless Metal Hose, Inc. is forbidden.

**PACKLESS INDUSTRIES**

|                     |                 |
|---------------------|-----------------|
| DRWN BY             | ENG. APPR       |
| E.Cardenas 01-26-12 | P.J.D. 01-26-12 |
| CHKD BY             | MFG. APPR       |
|                     |                 |

|                                |                    |
|--------------------------------|--------------------|
| TITLE                          | FINISH             |
| #A220SP8001 COAX-7500-S-13-182 | Block Enamel Point |
| #A222SP8001 COCX-7500-S-13-182 |                    |
| SCALE                          | DWG. NO.           |
| 1/4                            | B-283508           |

|     |    |     |   |
|-----|----|-----|---|
| SHT | OF | REV | UNLESS OTHERWISE SPECIFIED TOLERANCES ON FRACTIONS ± 3/8 DECIMALS ANGLES MATERIAL |
| 1   | 1  |     |   |